



Corridor Lights 1, 2, 3, 4, or 6 Lights L-101, L-102, L-103, L-422*, and L-423*

*L-422 and L-423 are non-UL



*Photos are not to scale



Description: Available with one, two, three, four, or six lamps and a full range of optional silk-screened designations. *CORNELL* Corridor Lights feature translucent wedge-shaped covers in red or white.

Operation: The Light will illuminate when associated station is activated.

Maintenance: Dome covers are easily removed from the front, for simplified lamp replacement.

Options: Corridor lights can be made in 1-6 light configurations with white or red domes. Lights can be made red, blue, amber, yellow,

or green with additional filters. Domes can also be silkscreened.

*4-6 Light configurations are required to be on at least a 4 gang plate.

Mounting: L-101, L-102, and L-103 models mount on standard, single-gang boxes or plaster rings, with a required depth of 1 inch. L-422 and L-423 models mount on a standard 4-gang box or plaster rings with a minimum of 1" depth.

Engineering Specifications: The contractor shall furnish and install the *CORNELL* Series 4000 Corridor Lights with one (L-101), two (L-102), three (L-103), four (L-422) or six (L-423) lamps. The domes shall be (red) or (white), with optional designations silk-screened on the surface. The stainless steel faceplates shall mount on a standard, single-gang electrical wall box or single-gang plaster ring, with external connection achieved via pigtailed. The dome covers shall be removable from the front for easy replacement of the lamps.

Technical Information:

- Power Requirements: 24VDC
- Operating Environment: 50-120°F Indoor Non-condensing
- Physical Faceplate Dimensions: 4 ½ "H x 2 ¾ "W (1 Gang)
- Mounting: Single-Gang back box with 1" minimum depth
- Wiring: #22 AWG Minimum



Available in 1-6 gang sizes:

**stations are only UL Listed in the 1 gang size*

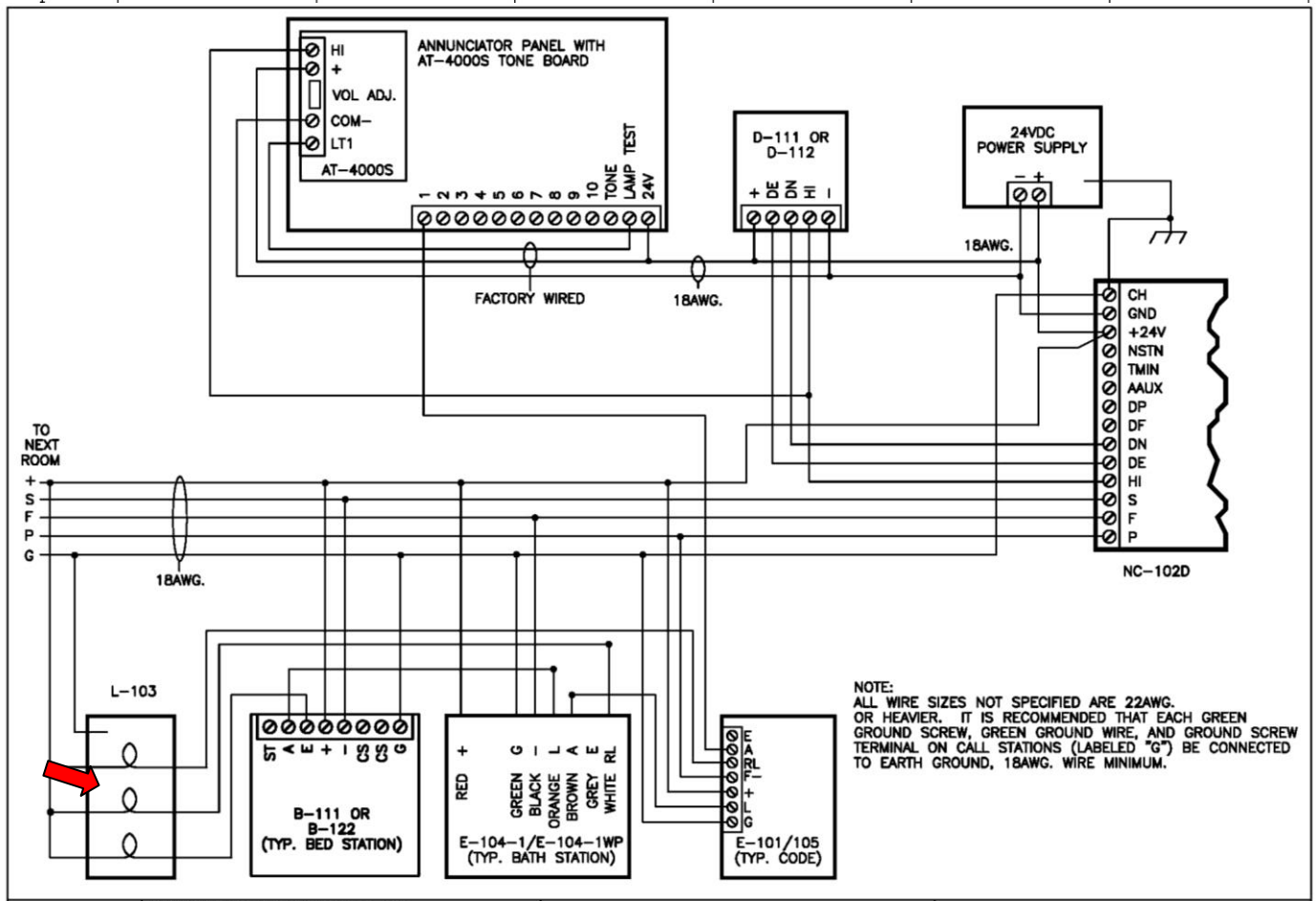
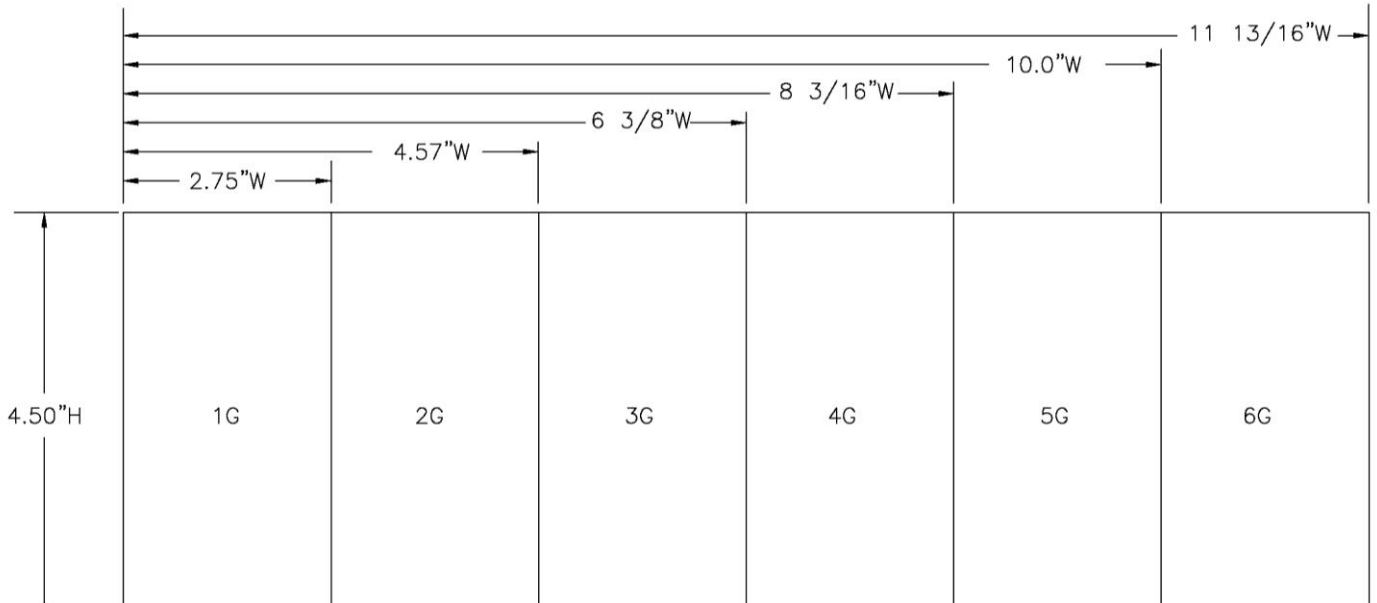

 CORNELL Communications, Inc. sales@cornell.com 414-351-4660 Web: www.cornell.com 414-351-4657(fax)	DATE: APRIL 1, 2008	SYSTEM: 4000 NURSE CALL
	TITLE: TRIPLE STATUS NC-102D / L-103	DRAWING # 90038-08

CORNELL COMMUNICATIONS, INC.

Milwaukee, Wisconsin USA • 800-558-8957 • 414-351-4660 • Fax 414-351-4657
 www.cornell.com • sales@cornell.com

